

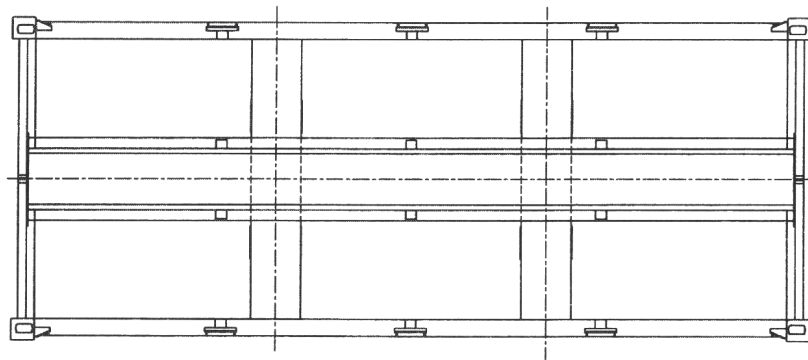

MODEL 5001-E-17

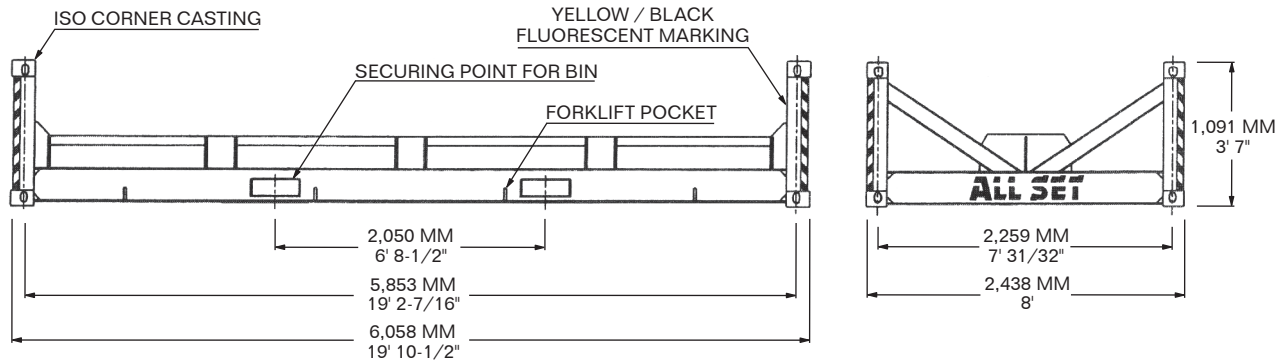

DESIGNED FOR BIN E-16
SIZE: 52" L x 34-1/4" W x 31" H

OWNER TO GIVE CONTAINER NUMBER.
CSC APPROVED.
TO BE LIFTED WITH 20' CONTAINER SPREADER.

MAX. GROSS WEIGHT: 20,000 Kg / 44,100 LBS
TARE: 1,550 Kg / 3,419 LBS
CAPACITY: 8 EA. E-16 BINS
 MAX 17,100 Kg PRODUCTS INSIDE THE BINS
 MAX 250 PCS C5AM-DF PER BIN = 2,000 / RACK

MATERIAL: MILD STEEL
FINISH: HOT-DIP GALVANIZED (HDG)





MODEL 5001-E-17-MAERSK

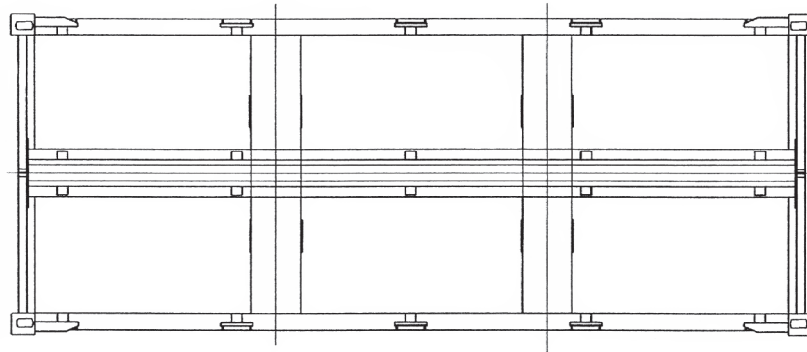
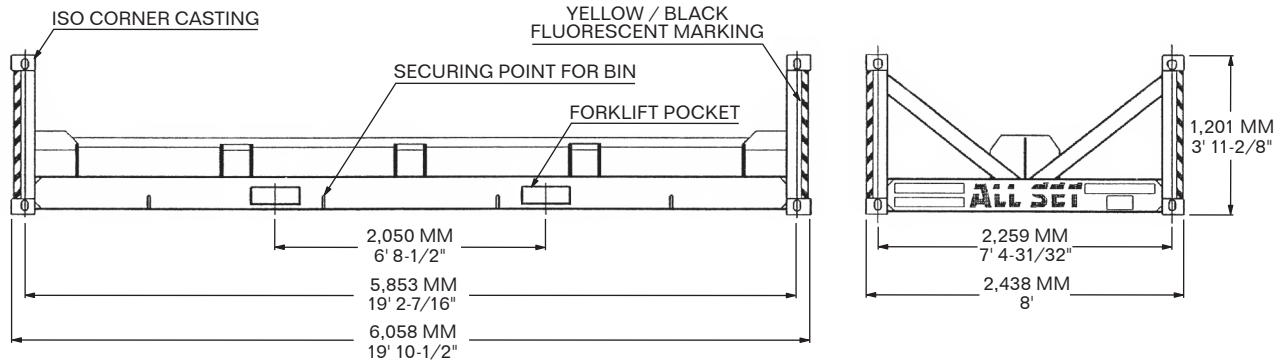

DESIGNED FOR BIN
5001-E-16-MAERSK
 SIZE: 47-1/4" L x 39-3/8" W x 31-1/2" H
 (1,200 MM x 1,000 MM x 800 MM)

OWNER TO GIVE CONTAINER NUMBER.
 CSC APPROVED.
 TO BE LIFTED WITH 20' CONTAINER SPREADER.

MAX. GROSS WEIGHT: 20,000 Kg / 44,100 LBS
TARE: 1,480 Kg / 3,263 LBS
CAPACITY: 8 EA. E-16-MAERSK BINS
 MAX 17,100 Kg PRODUCTS INSIDE THE BINS
 MAX 280 PCS C5AM-DF PER BIN = 2,240 PCS / E-17-MAERSK

MATERIAL: MILD STEEL
FINISH: HOT-DIP GALVANIZED (HDG)





MODEL 5001-E-182

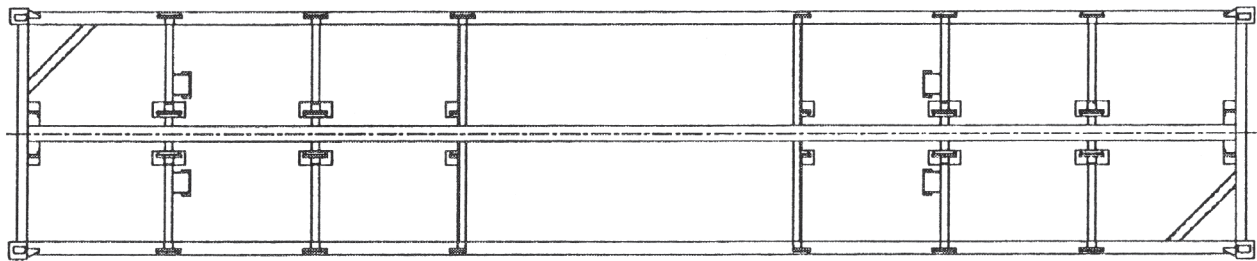
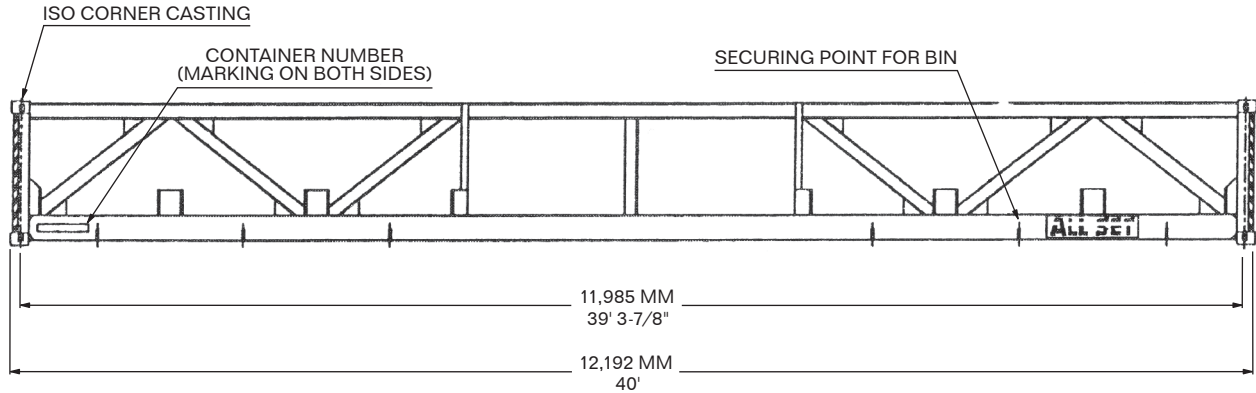

DESIGNED FOR BIN E-16
SIZE: 52" L x 34-1/4" W x 31" H

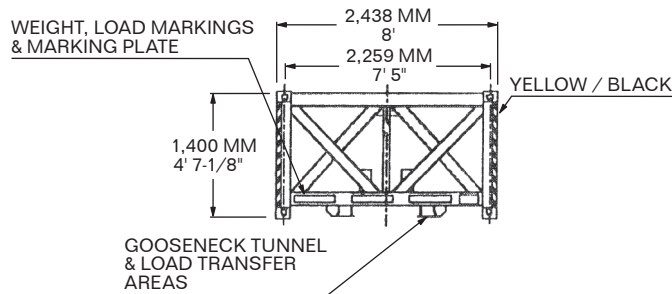

OWNER TO GIVE CONTAINER NUMBER.
TO BE LIFTED WITH 40' CONTAINER SPREADER.

MAX. GROSS WEIGHT: 27,000 Kg / 59,535 LBS
TARE: 2,800 Kg / 6,174 LBS
CAPACITY: 12 EA. E-16 BINS
 MAX 22,200 Kg PRODUCTS INSIDE THE BINS
 MAX 250 PCS C5AM-DF PER BIN = 3,000 / RACK

MATERIAL: MILD STEEL
FINISH: HOT-DIP GALVANIZED (HDG)





MODEL 5001-E-18

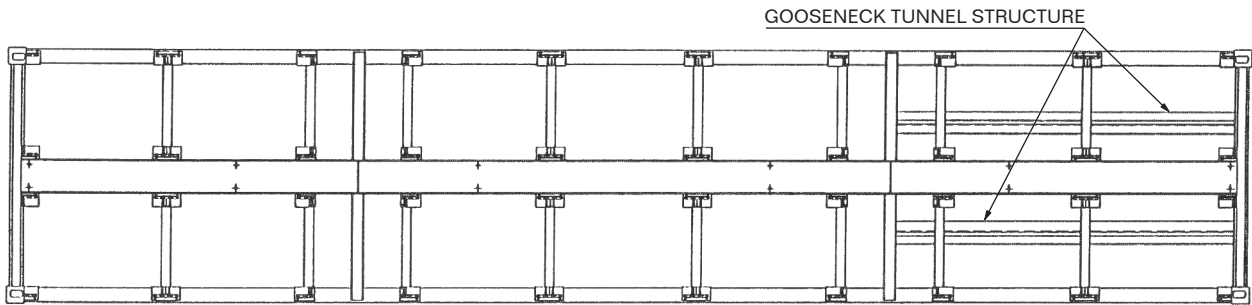
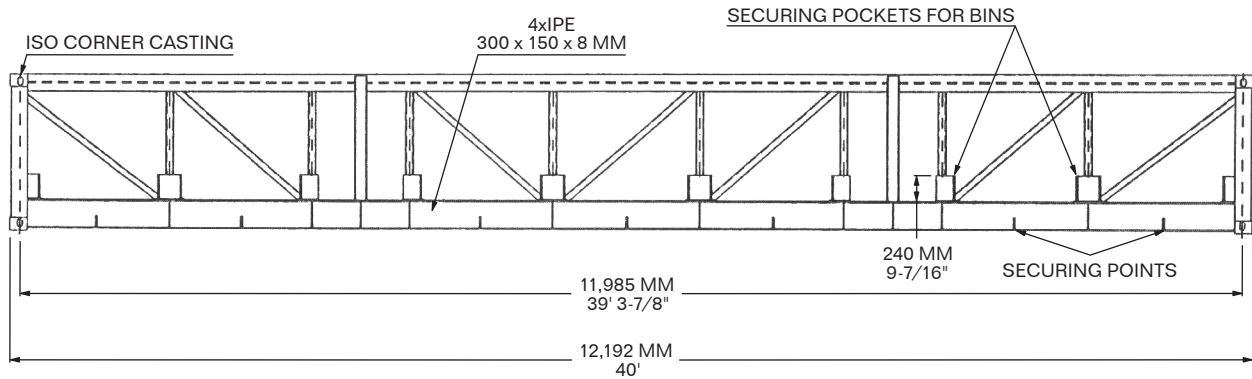

DESIGNED FOR BIN E-16
SIZE: 52" L x 34-1/4" W x 31" H

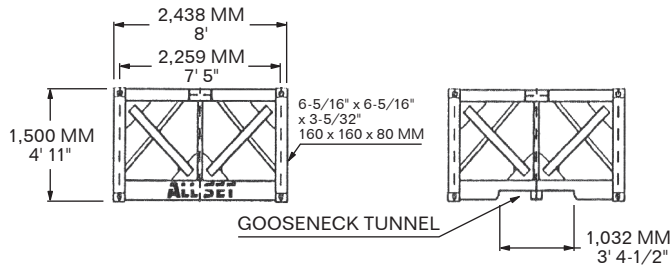

OWNER TO GIVE CONTAINER NUMBER.
TO BE LIFTED WITH 40' CONTAINER SPREADER.

MAX. GROSS WEIGHT: 30,480 Kg / 67,137 LBS

TARE: 4,800 Kg / 10,582 LBS

CAPACITY: 14 EA. E-16 BINS

MAX 23,350 Kg PRODUCTS INSIDE THE BINS

MAX 250 PCS C5AM-DF PER BIN = 3,500 / RACK

MATERIAL: MILD STEEL

FINISH: HOT-DIP GALVANIZED (HDG)





MODEL 5001-E-16
MODEL 5001-SB-8/1
MODEL 5001-E-16-MAERSK

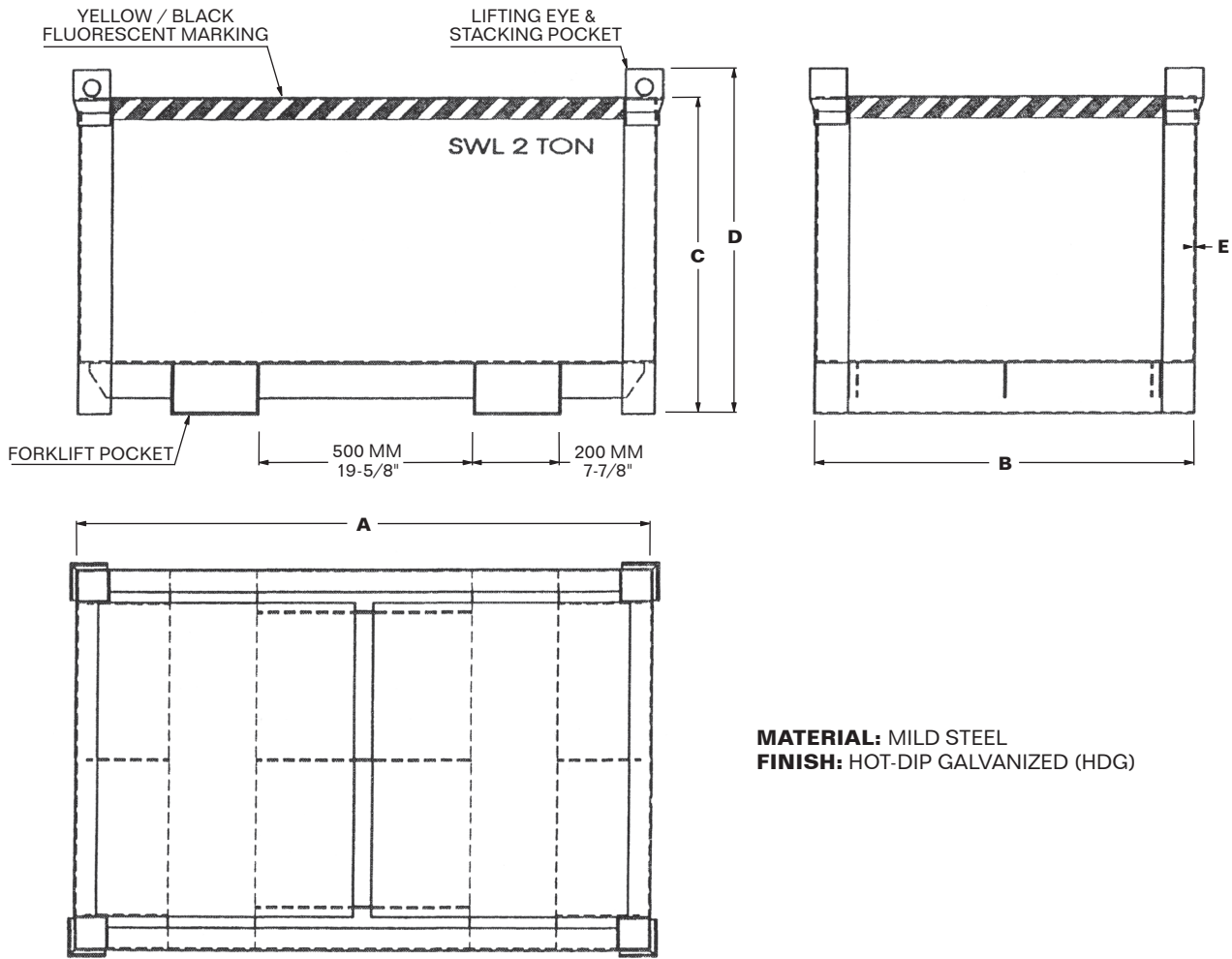

MATERIAL: MILD STEEL
FINISH: HOT-DIP GALVANIZED (HDG)

SIZE TABLE

MODEL	A	B	C	D	E	CUBE SIZE M ³ / CUFT	EMPTY WEIGHT Kg / LBS	C5AM-DF TWISTLOCK CAPACITY
5001-E-16	1,320 MM 52"	870 MM 34-1/4"	725 MM 28-1/2"	790 MM 31"	3.20 MM 1/8"	0.70 25	164 Kg 362 LBS	250
5001-SB-8/1	1,320 MM 52"	1,090 MM 43"	800 MM 31-1/2"	855 MM 33-11/16"	3.20 MM 1/8"	1.00 35	169 Kg 373 LBS	350
5001-E-16-MAERSK	1,200 MM 47-1/4"	1,000 MM 39-3/8"	800 MM 31-1/2"	900 MM 35-3/8"	3.00 MM 1/8"	0.8 28	155 Kg 342 LBS	280

